

EXAMPLE:
Component Parts (Small #) Are Included
When Ordering The Assembly (Large #).

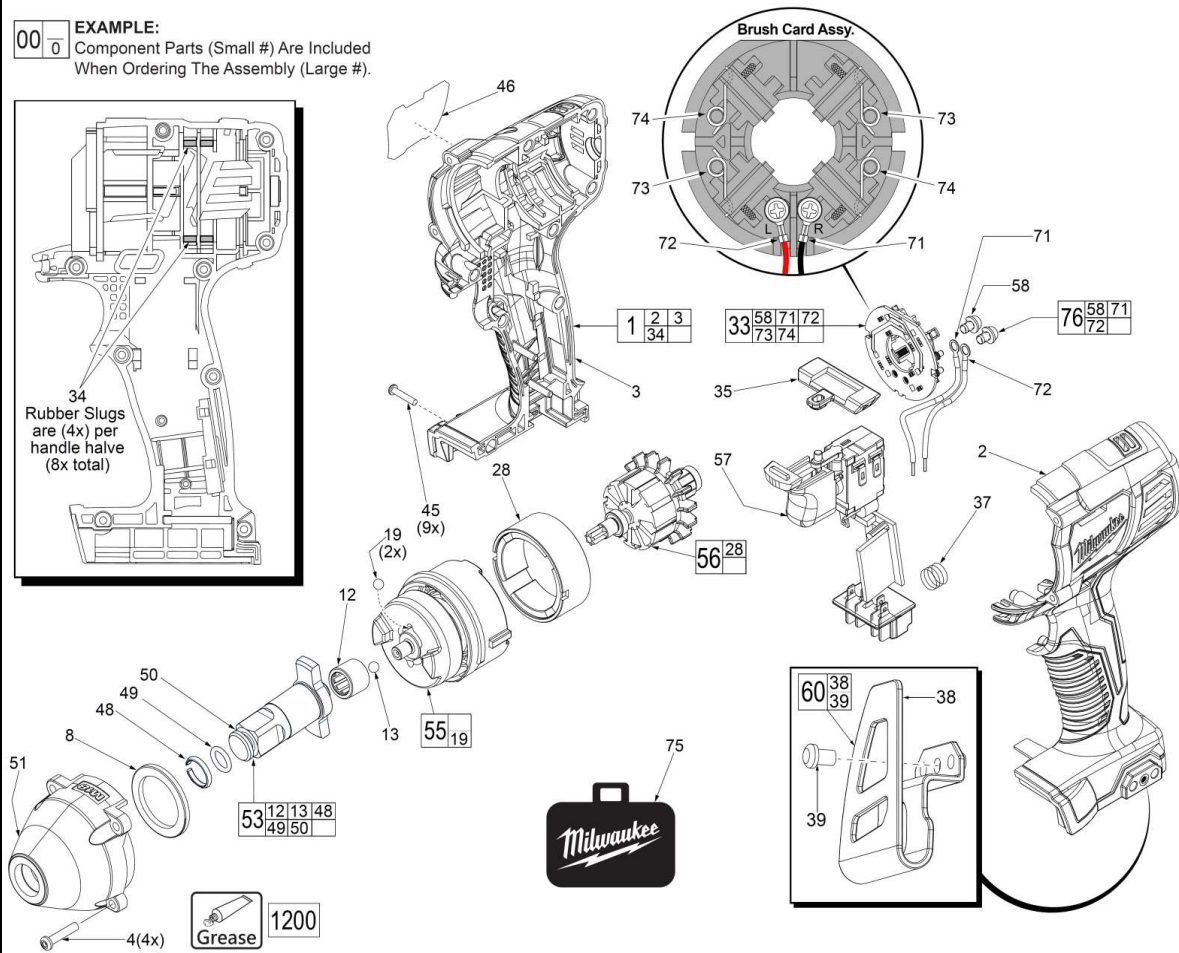

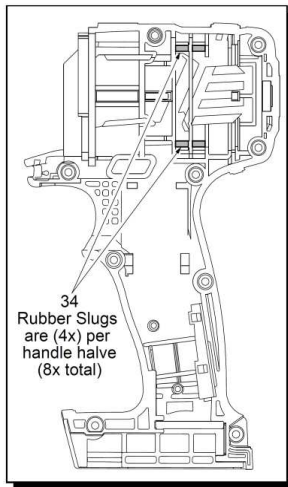

M18 BIW12

SERVICE PARTS LIST

TTI Model Number: 018 089 043, 044, 045, 046, 060, 062

M18 COMPACT 1/2" IMPACT WRENCH

Bulletin Date:

Nov-17

Starting Serial Number:

VERSION A - E2014

ITEM	PART NUMBER	PART DISCRIPTION	QTY (PCS)
1	202730001	HOUSING ASSEMBLY	1
2	-	LEFT HOUSING HALVE	1
3	-	RIGHT HANDLE HALVE	1
4	662047001	M4 X 20MM SCREW	4
8	642067001	PLASTIC WASHER	1
12	680582005	NEEDLE BEARING	1
13	670219001	5MM STEEL BALL	1
19	680015001	4.7MM STEEL BALL	2
28	741256004	FIELD	1
33	202742002	BRUSH CARD ASSEMBLY	1
34	560076001	RUBBER SLUG	8
35	525462001	FORWARD / REVERSE SHUTTLE	1
37	691093001	TERMINAL BLOCK SPRING	1
38	-	BELT CLIP	1
39	661082002	6-32 X 5/16" SCREW	1
45	660851001	M3 X16M SCREW	9
46	941048042	SERVICE NAMEPLATE	1
48	691983001	FRICTION RING	1
49	570698001	O-RING	1
50	671562063	ANVIL	1
51	202725001	FRONT GEARCASE WITH BUSHING	1
53	200704002	ANVIL ASSY	1
55	200713002	GEARBOX ASSEMBLY	1
56	201303001	ARMATURE ASSEMBLY	1
57	270001600	ELECTRONICS ASSEMBLY	1
58	662308001	M3 X 5MM SCREW	2
60	202728001	BELT CLIP ASSEMBLY	1
71	-	LEADWIRE ASSEMBLY - BLACK - RIGHT SIDE	1
72	-	LEADWIRE ASSEMBLY - RED - LEFT SIDE	1
73	-	BRUSH SPRING - RIGHT	2
74	-	BRUSH SPRING - LEFT	2
75	302862012	CARRYING CASE	1
76	202741002	LEADWIRE/SCREW/WASHER KIT	1
77	940221345	WARNING LABEL (NOT SHOWN)	1
1200	-	TYPE J GREASE	

INSTALLING BRUSH SPRINGS ON A BRUSH CARD ASSEMBLY WITH FOUR (4) BRUSHES

There are two Right Hand Brush Springs and two Left Hand Brush Springs. If needed, follow the instructions below for proper installation.

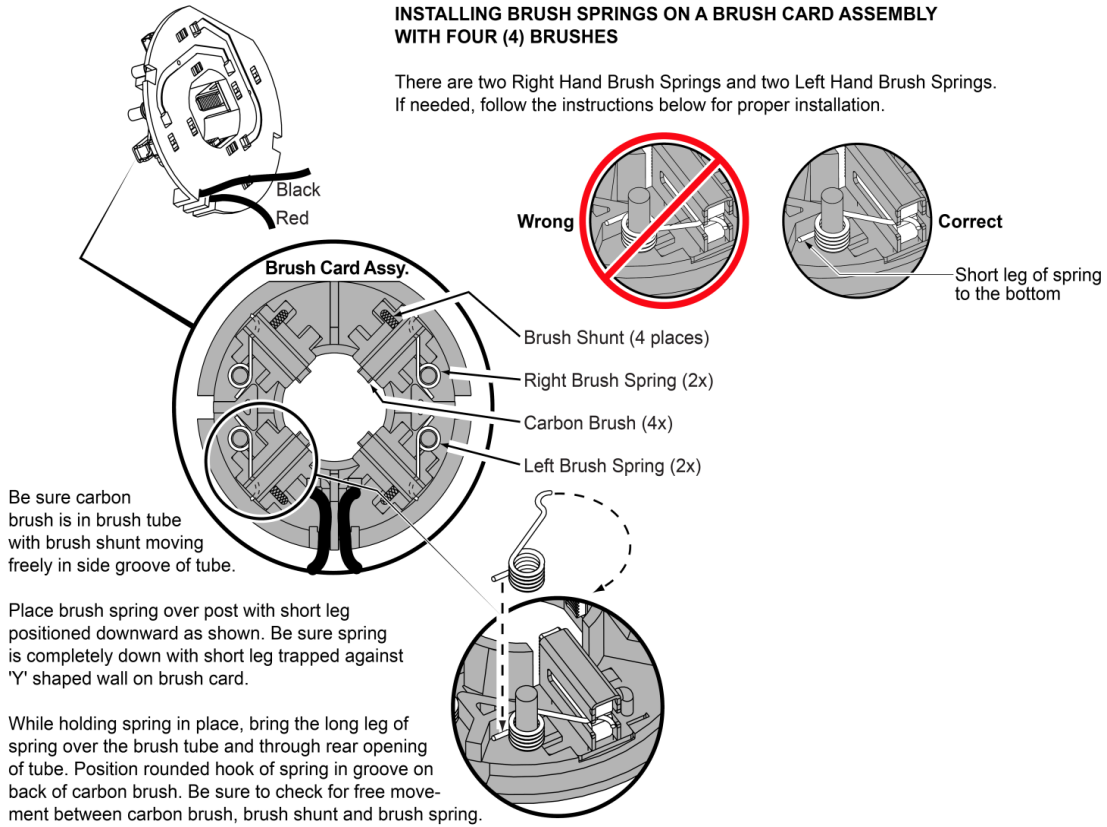

Be sure carbon brush is in brush tube with brush shunt moving freely in side groove of tube.

Place brush spring over post with short leg positioned downward as shown. Be sure spring is completely down with short leg trapped against 'Y' shaped wall on brush card.

While holding spring in place, bring the long leg of spring over the brush tube and through rear opening of tube. Position rounded hook of spring in groove on back of carbon brush. Be sure to check for free movement between carbon brush, brush shunt and brush spring.

FIG. NOTES:

- 15,16,17 See service note and illustration on the back of bulletin to aid with the removal and installation of the the Brush Card (15), Armature (16) and Field (17).
- 17 Field (17) to be positioned with side cut-outs to the front.
- 20,21 Position Ring Gear (21) with three lugs face down to interlock in the bottom of Rear Case (20).
- 20,43 Be sure to match the raised contours on the bottom of Rear Case (20) with raised contour on bottom of Front Case (43) when assembling.
- 29,30 Make sure concave side of Washer (29) faces Spring (30).
- 42,43 Tapped end of Front Washer (42) to face Front Case (43).

FIG. LUBRICATION (Type 'J' Grease, Item 1200):

- 21,26 Lightly coat I.D. of the Ring Gear (21) and center of the two Planet Gears (26) with grease.
- 27 Place a dab of grease in the ball grooves of the Cam Shaft (27).
- 36,37 Lightly coat front washer surface of Anvil (36) with grease, place a dab in the Ball holes of Anvil and in Needle Bearing inside the Anvil.
- 43 Coat inside grooves of Bushing (inside of 43) with grease.

